



Product Specification

M190PW01 V8

AU OPTRONICS CORPORATION

(V) Preliminary Specification

() Final Specification

Module	19" WXGA+ Color TFT-LCD
Model Name	M190PW01 V8

Customer	Date	Approved by	Date
_____	_____	<u>ChiYi Wu</u>	Oct 20.11.2014
Approved by		Prepared by	Date
_____	_____	<u>Archer Cheng</u>	Oct 20.11.2014
Note: This Specification is subject to change without notice.		Desktop Display Business Group / AU Optronics corporation	



Contents

1.0 Handling Precautions.....	4
2.0 General Description	5
2.1 Display Characteristics.....	5
2.2 Optical Characteristics	6
3.0 Functional Block Diagram	10
4.0 Absolute Maximum Ratings.....	11
4.1 TFT LCD Module.....	11
4.2 Backlight Unit.....	11
4.3 Absolute Ratings of Environment	11
5.0 Electrical characteristics.....	12
5.1 TFT LCD Module.....	12
5.1.1 Power Specification.....	12
5.1.2 Signal Electrical Characteristics.....	13
5.2 Backlight Unit.....	14
6.1 Pixel Format Image.....	15
6.2 The input data format	15
6.3 Signal Description.....	16
6.4 Timing Characteristics	18
6.5 Timing diagram.....	19
6.6 Power ON/OFF Sequence	20
7.0 Connector & Pin Assignment	21
7.1 TFT LCD Module.....	21
7.1.1 Pin Assignment	21
7.2 Backlight Unit.....	22
8.0 Reliability Test.....	23
9.0 Shipping Label	24
10. Packing Specification.....	25
11.0 Mechanical Characteristics	26



Product Specification

M190PW01 V8

AU OPTRONICS CORPORATION

Record of Revision

Version and Date		Old description	New Description	Remark
Page 0.12014/10/20	All	First Edition for Customer	N/A	



1.0 Handling Precautions

- 1) Since front polarizer is easily damaged, pay attention not to scratch it.
- 2) Be sure to turn off power supply when inserting or disconnecting from input connector.
- 3) Wipe off water drop immediately. Long contact with water may cause discoloration or spots.
- 4) When the panel surface is soiled, wipe it with absorbent cotton or other soft cloth.
- 5) Since the panel is made of glass, it may break or crack if dropped or bumped on hard surface.
- 6) Since CMOS LSI is used in this module, take care of static electricity and insure human earth when handling.
- 7) Do not open or modify the Module Assembly.
- 8) Do not press the reflector sheet at the back of the module to any directions.
- 9) In case if a Module has to be put back into the packing container slot after once it was taken out from the container, do not press the center of the LED lightbar edge. Instead, press at the far ends of the LED light bar edge softly. Otherwise the TFT Module may be damaged.
- 10) At the insertion or removal of the Signal Interface Connector, be sure not to rotate nor tilt the Interface Connector of the TFT Module.
- 11) After installation of the TFT Module into an enclosure, do not twist nor bend the TFT Module even momentary. At designing the enclosure, it should be taken into consideration that no bending/twisting forces are applied to the TFT Module from outside. Otherwise the TFT Module may be damaged.
- 12) Small amount of materials having no flammability grade is used in the LCD module. The LCD module should be supplied by power complied with requirements of Limited Power Source (IEC60950 or UL1950), or be applied exemption.
- 13) Pls avoid touching COF position while you are doing mechanical design
- 14) When storing modules as spares for a long time, the following precaution is necessary:
Store them in a dark place. Do not expose the module to sunlight or fluorescent light. Keep the temperature between 5°C and 35°C at normal humidity.



Product Specification

M190PW01 V8

AU OPTRONICS CORPORATION

2.0 General Description

This specification applies to the 19 inch-wide Color TFT-LCD Module M190PW01.

The display supports the WXGA+ (1440(H) x 900(V)) screen format and 16.7M colors(RGB 6-bits+HiFRC). All input signals are 2-Channel LVDS interface compatible. This module does not contain an inverter board for backlight.

2.1 Display Characteristics

The following items are characteristics summary on the table under 25°C condition:

ITEMS	Unit	SPECIFICATIONS
Screen Diagonal	[mm]	
Active Area	[mm]	408.24 (H) x 255.15(V)
Pixels H x V		1440x3(RGB) x 900
Pixel Pitch	[um]	283.5 (per one triad) ×283.5
Pixel Arrangement		R.G.B. Vertical Stripe
Display Mode		TN Mode, Normally White
White Luminance (Center)	[cd/m ²]	250 cd/m ² (Typ.)
Contrast Ratio		1000 (Typ.)
Optical Response Time	[msec]	5ms (Typ., on/off) (
Nominal Input Voltage VDD	[Volt]	+5.0 V
Power Consumption (VDD line + LED line)	[Watt]	15.1W (Typ)
Weight		
Physical Size	[mm]	428.0(W) x 278.0(H) x 10.3(D) (Typ)
Electrical Interface		Dual channel LVDS
Support Color		16.7M colors (RGB 6-bit + Hi_FRC)
Surface Treatment		Anti-Glare, 3H
Temperature Range		
Operating	[°C]	0 to +50
Storage (Shipping)	[°C]	-20 to +60
RoHS Compliance		RoHS Compliance
TCO5.1 Compliance		TCO5.1 Compliance



Product Specification

M190PW01 V8

AU OPTRONICS CORPORATION

2.2 Optical Characteristics

The optical characteristics are measured under stable conditions at 25°C:

Item	Unit	Conditions	Min.	Typ.	Max.	Note
Viewing Angle	[degree]	Horizontal (Right) CR = 10 (Left)	70 70	85 85	- -	2
		Vertical (Up) CR = 10 (Down)	70 70	80 80	- -	
Contrast ratio		Normal Direction	600	1000	-	3
Response Time	[msec]	Raising Time (T _{RR})	-	3.6	5.7	4
		Falling Time (T _{RF})	-	1.4	2.3	
		Raising + Falling	-	5	8	
		Gray to Gray(16x16 avg.)	-	-	-	
Color / Chromaticity Coordinates (CIE)		Red x	0.612	0.642	0.672	5
		Red y	0.315	0.345	0.375	
		Green x	0.291	0.321	0.351	
		Green y	0.595	0.625	0.655	
		Blue x	0.121	0.151	0.181	
Color Coordinates (CIE) White			0.283	0.313	0.343	
		White y	0.299	0.329	0.359	
Central Luminance	[cd/m ²]		200	250	-	6
Luminance Uniformity	[%]		75	80	-	7
Crosstalk (in 75 Hz)	[%]				1.5	8
Flicker	dB				-20	9



Product Specification

M190PW01 V8

AU OPTRONICS CORPORATION

Note 1: Measurement method

The LCD module should be stabilized at given temperature for 30 minutes to avoid abrupt temperature change during measuring (at surface 35°C). In order to stabilize the luminance, the measurement should be executed after lighting Backlight for 30 minutes in a stable, windless and dark room.

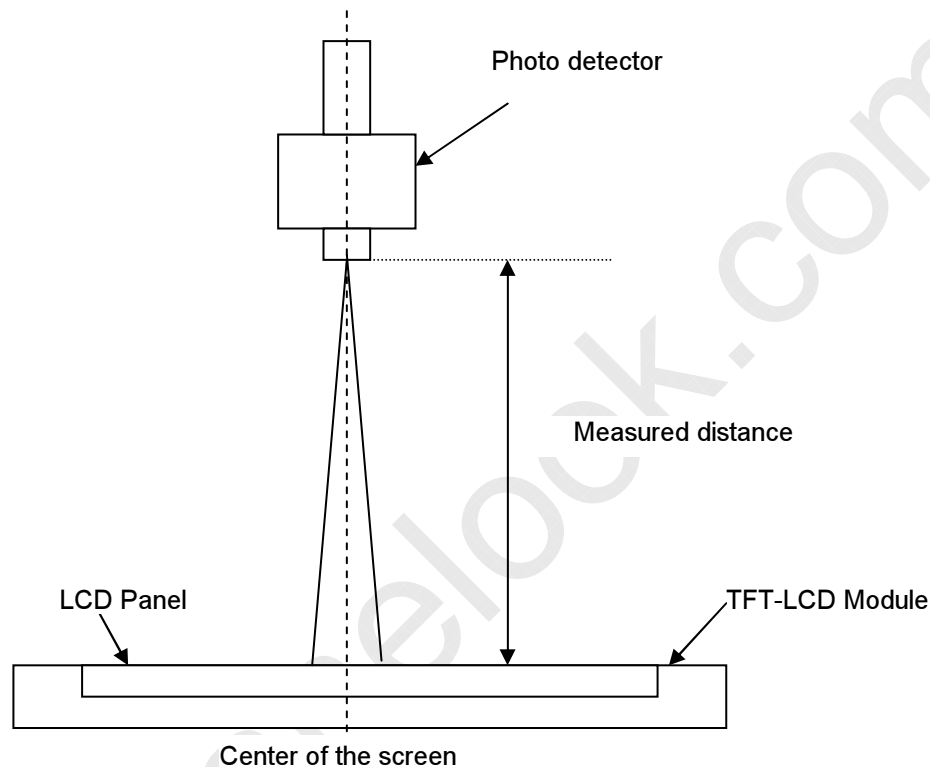

Note 2: Definition of viewing angle measured by ELDIM (EZContrast 88)

Viewing angle is the measurement of contrast ratio ≥ 10 , at the screen center, over a 180° horizontal and 180° vertical range (off-normal viewing angles). The 180° viewing angle range is broken down as follows; 90° (θ) horizontal left and right and 90° (ϕ) vertical, high (up) and low (down). The measurement direction is typically perpendicular to the display surface with the screen rotated about its center to develop the desired measurement viewing angle.

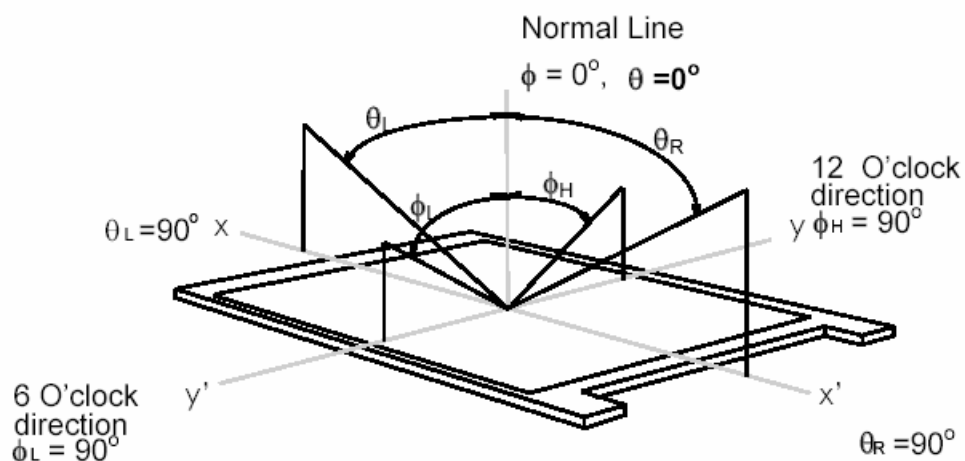



Product Specification

M190PW01 V8

AU OPTRONICS CORPORATION

Note 3: Contrast ratio is measured by TOPCON SR-3

Note 4: Definition of Response time measured by Westar TRD-100A

The output signals of photo detector are measured when the input signals are changed from "Full Black" to "Full White" (rising time, Tr_R), and from "Full White" to "Full Black" (falling time, Tr_F), respectively. The response time is interval between the 10% and 90% (1 frame at 60 Hz) of amplitudes.

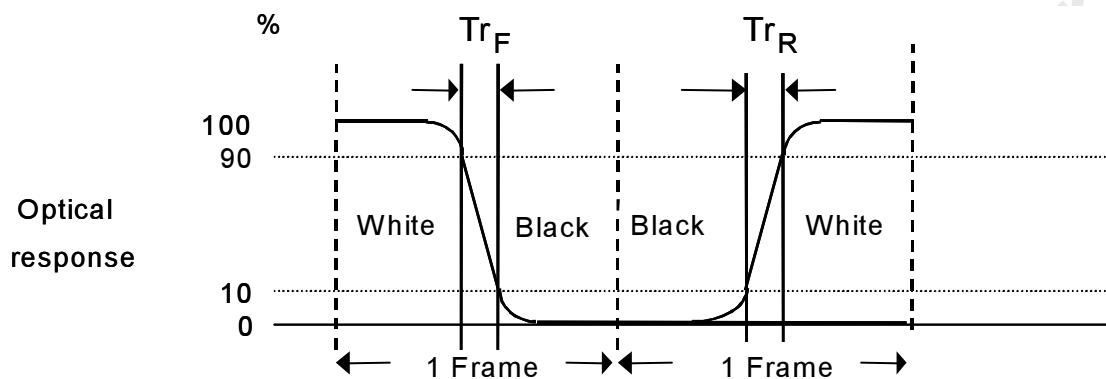

$Tr_R + Tr_F = 5$ msec (typ.).

Algorithm: | Gray Level A – Gray Level B | $\square 16$, then the average gray to gray response time is 2 ms, (F= 60 Hz).

Note 5: Color chromaticity and coordinates (CIE) is measured by TOPCON SR-3

Note 6: Central luminance is measured by TOPCON SR-3

Note 7: Luminance uniformity of these 9 points is defined as below and measured by TOPCON SR-3

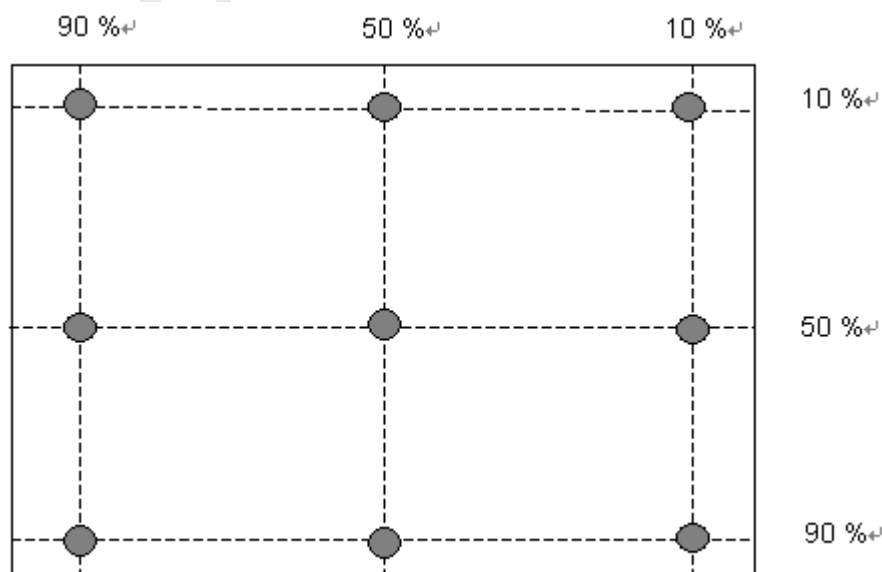



Product Specification

M190PW01 V8

AU OPTRONICS CORPORATION

$$\text{Uniformity} = \frac{\text{Minimum Luminance in 9 points (1-9)}}{\text{Maximum Luminance in 9 Points (1-9)}}$$

Note 8: Crosstalk is defined as below and measured by TOPCON SR-3

$$CT = |YB - YA| / YA \times 100 (\%)$$

Where

YA = Luminance of measured location without gray level 0 pattern (cd/m2)

YB = Luminance of measured location with gray level 0 pattern (cd/m2)

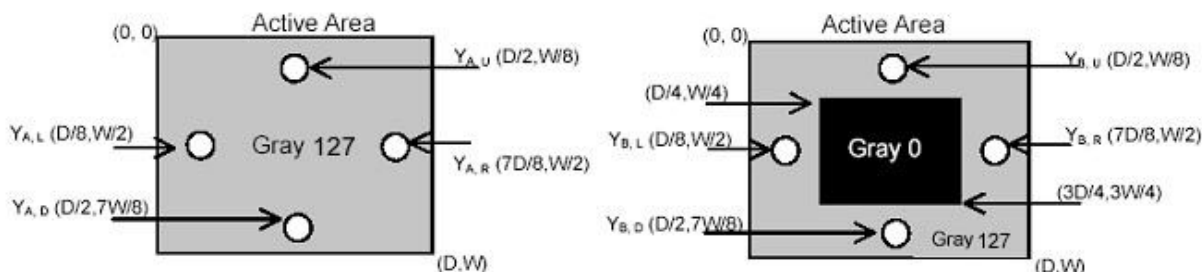

Note 9: Test Pattern: Subchecker Pattern measured by TOPCON SR-3

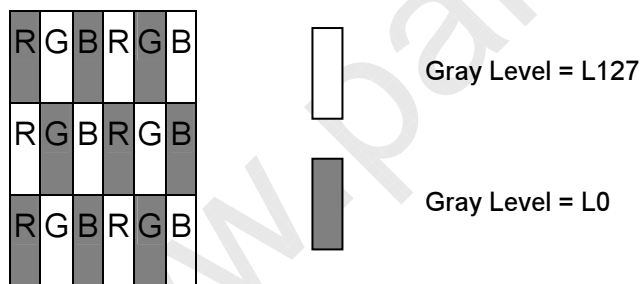

Method: Record dBV & DC value with TRD-100

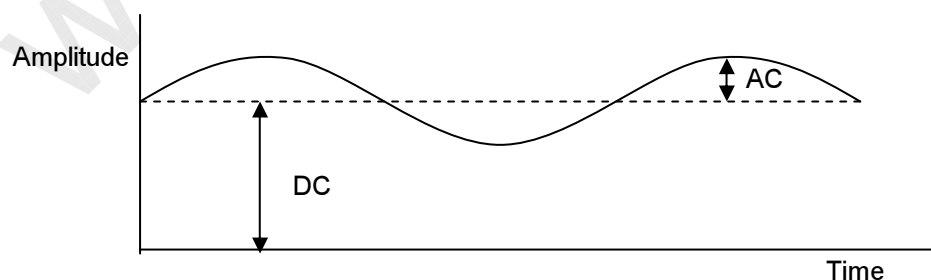

$$\text{Flicker (dB)} = 20 \log \frac{\text{AC Level (at 30 Hz)}}{\text{DC Level}}$$



Product Specification

M190PW01 V8

AU OPTRONICS CORPORATION

3.0 Functional Block Diagram

The following diagram shows the functional block of the 19.0 inch Color TFT-LCD Module:

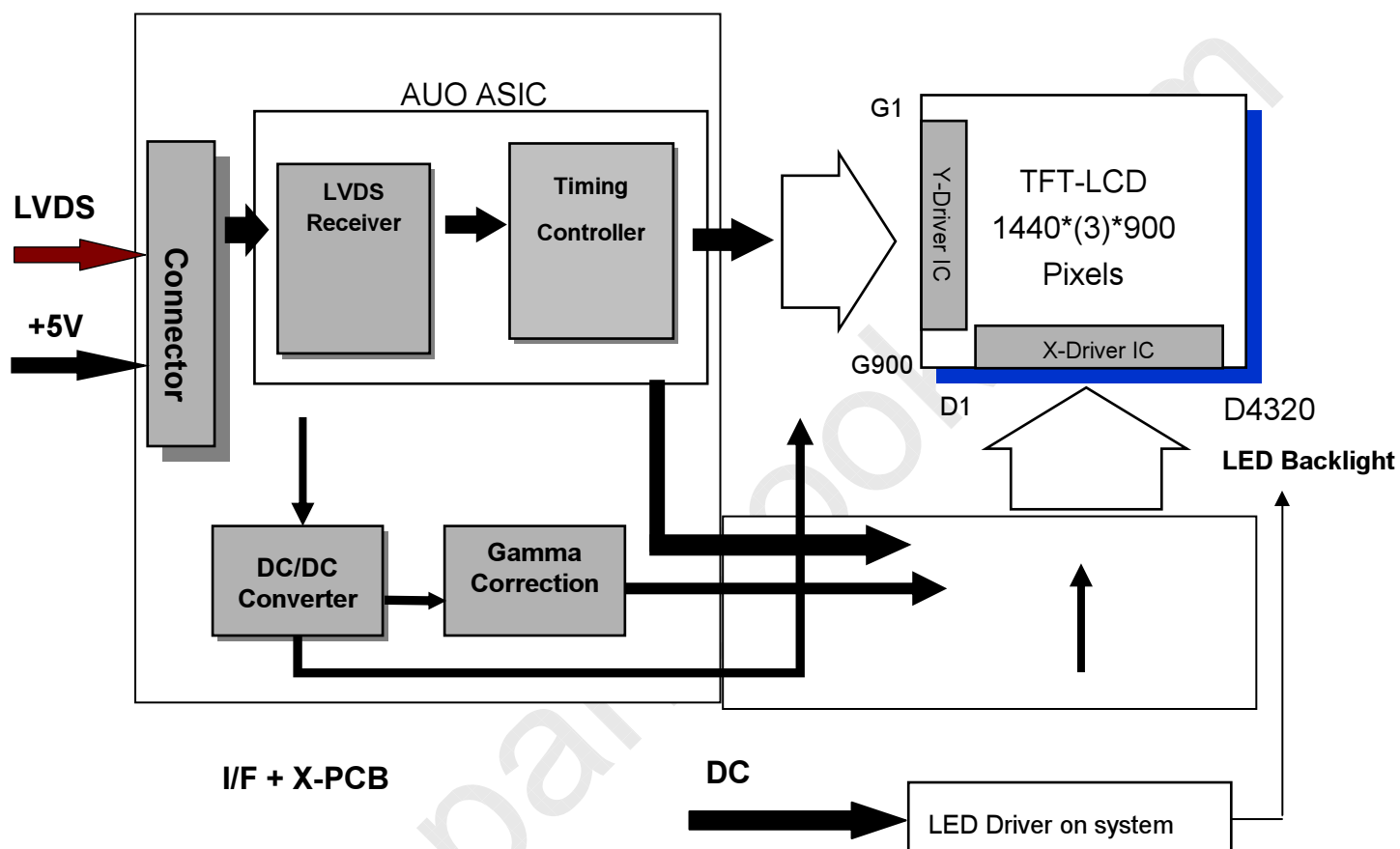

I/F PCB Interface:

FI-XPB30SRL-HF11(JAE)/ 093F30-B0T01A (SC)

Mating Type:

FI-X30HL-T(JAE)(Locked Type)



Product Specification

M190PW01 V8

AU OPTRONICS CORPORATION

4.0 Absolute Maximum Ratings

Absolute maximum ratings of the module are as following:

4.1 TFT LCD Module

Item	Symbol	Min	Max	Unit	Conditions
Logic/LCD Drive Voltage	VDD	0	5.5	[Volt]	Note 1,2

4.2 Backlight Unit

Item	Symbol	Min	Max	Unit	Conditions
LED Current	ILED	-	80	[mA] rms	Note 1,2

4.3 Absolute Ratings of Environment

Item	Symbol	Min.	Max.	Unit	Conditions
Operating Temperature	TOP	0	+50	[°C]	Note 3
Operation Humidity	HOP	5	90	[%RH]	
Storage Temperature	TST	-20	+60	[°C]	
Storage Humidity	HST	5	90	[%RH]	

Note 1: With in T_a (25 °C)

Note 2: Permanent damage to the device may occur if exceeding maximum values

Note 3: For quality performance, please refer to AUO IIS(Incoming Inspection Standard).

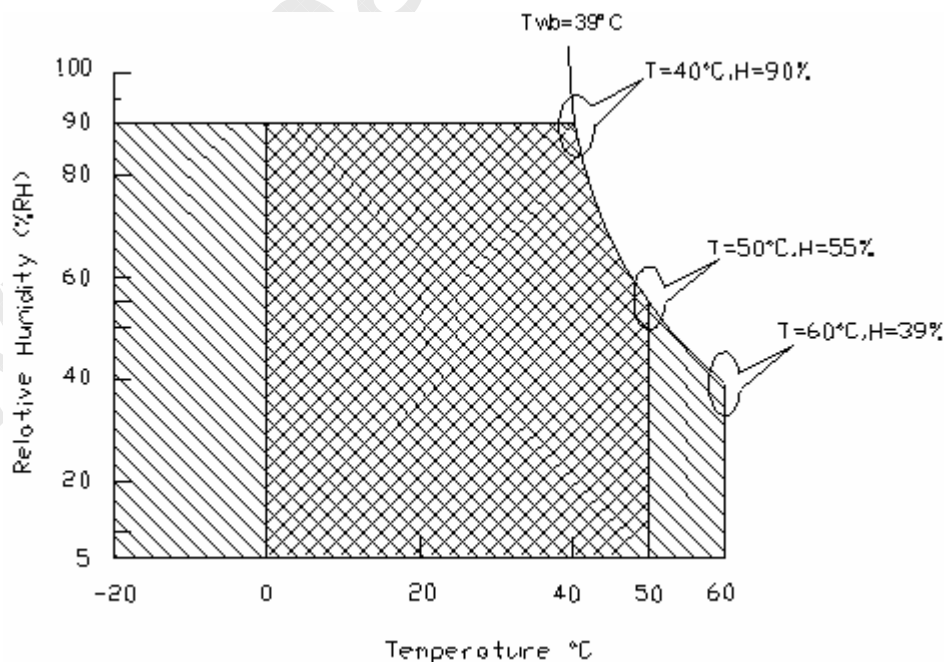

Operating Range



Storage Range

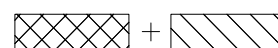



5.0 Electrical characteristics

5.1 TFT LCD Module

5.1.1 Power Specification

Input power specifications are as following:

Symbol	Parameter	Min	Typ	Max	Unit	Conditions
VDD	Logic/LCD Drive Voltage	4.5	5.0	5.5	[Volt]	+/-10%
IDD	Input Current	-	0.9	1.1	[A]	VDD= 5.0V, All Black Pattern At 60Hz
PDD	VDD Power	-	4.5	5.5	[Watt]	VDD= 5.0V, All Black Pattern At 60Hz , Note 1
IRush	Inrush Current	-	-	3	[A]	Note 2
VDDrp	Allowable Logic/LCD Drive Ripple Voltage	-	-	250	[mV] p-p	VDD=5.0, All black pattern at 60Hz

Note 1: The variance of VDD power consumption is $\pm 10\%$

Note 2: Measurement conditions:

The duration of rising time of power input is 470us.

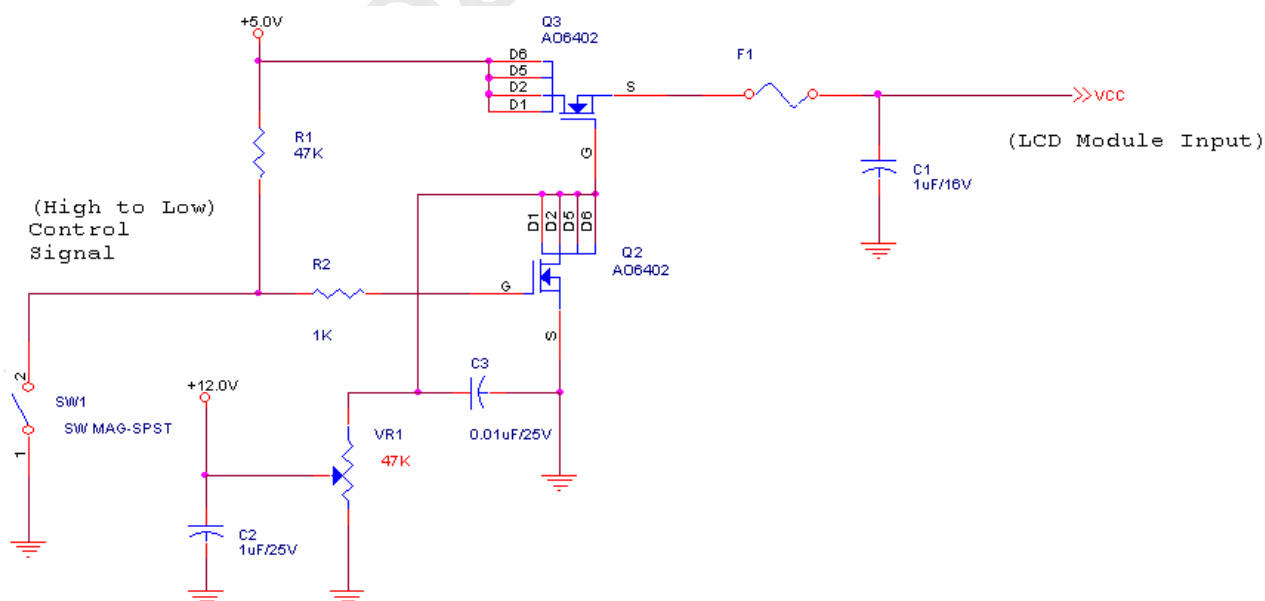



Product Specification

M190PW01 V8

AU OPTRONICS CORPORATION

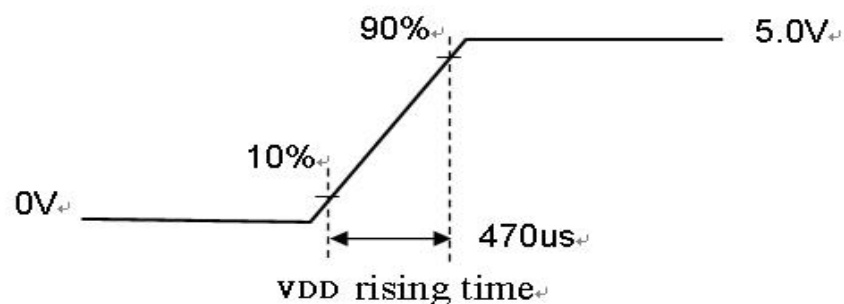

5.1.2 Signal Electrical Characteristics

Input signals shall be low or Hi-Z state when V_{in} is off

It is recommended to refer the specifications of SN75LVDS82DGG (Texas Instruments) in detail.

Each signal characteristics are as follows;

Symbol	Parameter	Min	Typ	Max	Units	Condition
VTH	Differential Input High Threshold	-	-	100	[mV]	VICM = 1.2V Note
VTL	Differential Input Low Threshold	-100	-	-	[mV]	VICM = 1.2V Note
VID	Input Differential Voltage	100	400	600	[mV]	Note
VICM	Differential Input Common Mode Voltage	1.0	1.2	1.5		VTH/VTL = 100mV Note

Note: LVDS Signal Waveform

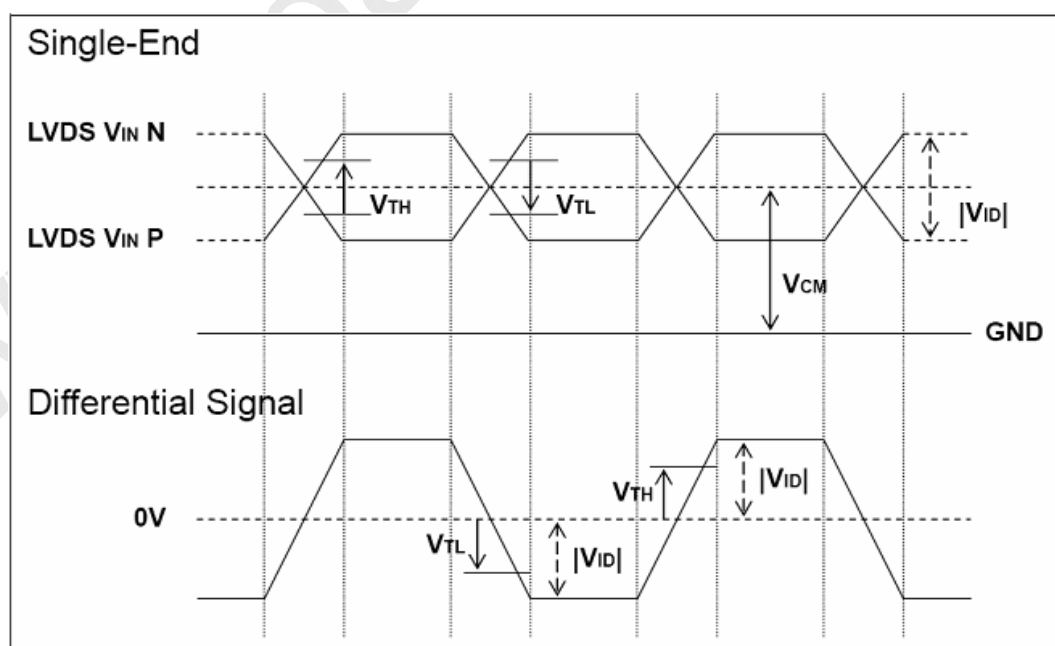



Product Specification

M190PW01 V8

AU OPTRONICS CORPORATION

5.2 Backlight Unit

Parameter guideline for LED driving is under stable conditions at 25°C (Room Temperature):

Symbol	Parameter	Min.□	Typ.	Max.	Unit	Note
$I_{R_{LED}}$	LED Operation Current	--	60	80	[mA]	Operating with fixed driving current
V_{LB}	Light Bar Operation Voltage (for reference)	39	44.2	46.8	[Volt] Note 1	
P_{BLU}	BLU Power consumption (for reference)	-	10.6	15	[Watt]	
LT_{LED}	LED life Time	30,000	--	--	[Hour] Note 2	

Note 1 : The value showed in the table is one light bar's operation voltage.

Note 2 : Based on the operating current is 60mA.

Note 3 : Definition of life time : brightness becomes 50% of its original value. The minimum life time of LED unit is on the condition of $I_{R_{LED}} = 60\text{mA}$ and $25\pm 2^\circ\text{C}$ (Room temperature).

Note 4: Each LED light bar consists of 52 pcs LED package (4 strings x 13 pcs / string)



Product Specification

M190PW01 V8

AU OPTRONICS CORPORATION

6.0 Signal Characteristic

6.1 Pixel Format Image

Following figure shows the relationship of the input signals and LCD pixel format.

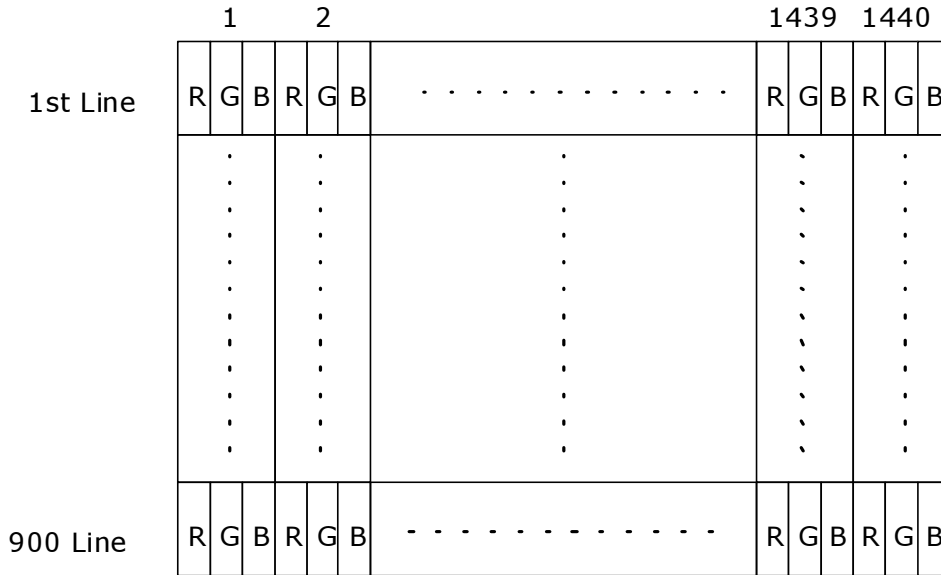

6.2 The input data format

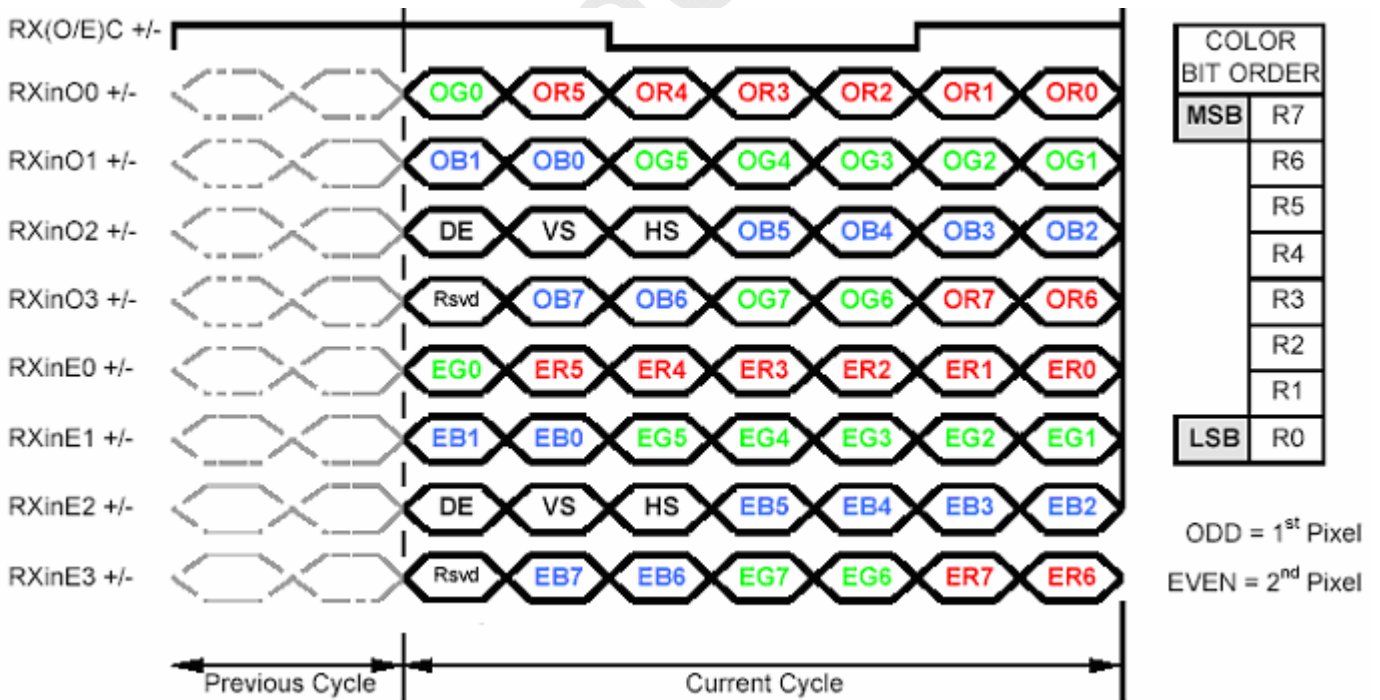

Note 1: R/G/B data 7:MSB, R/G/B data 0:LSB O = "First Pixel Data" E = "Second Pixel Data"



Product Specification

M190PW01 V8

AU OPTRONICS CORPORATION

6.3 Signal Description

The module using one LVDS receiver SN75LVDS82(Texas Instruments). LVDS is a differential signal technology for LCD interface and high speed data transfer device. LVDS transmitters shall be SN75LVDS83(negative edge sampling). The first LVDS port(RxOxxx) transmits odd pixels while the second LVDS port(RxExxx) transmits even pixels.

PIN #	SIGNAL NAME	DESCRIPTION
1	RxOIN0-	Negative LVDS differential data input (Odd data)
2	RxOIN0+	Positive LVDS differential data input (Odd data)
3	RxOIN1-	Negative LVDS differential data input (Odd data)
4	RxOIN1+	Positive LVDS differential data input (Odd data)
5	RxOIN2-	Negative LVDS differential data input (Odd data, H-Sync,V-Sync,DSPTMG)
6	RxOIN2+	Positive LVDS differential data input (Odd data, H-Sync,V-Sync,DSPTMG)
7	GND	Power Ground
8	RxOCLKIN-	Negative LVDS differential clock input (Odd clock)
9	RxOCLKIN+	Positive LVDS differential clock input (Odd clock)
10	RxOIN3-	Negative LVDS differential data input (Odd data)
11	RxOIN3+	Positive LVDS differential data input (Odd data)
12	RxEIN0-	
13	RxEIN0+	
14	GND	Power Ground
15	RxEIN1-	Negative LVDS differential data input (Even data)
16	RxEIN1+	Positive LVDS differential data input (Even data)
17	GND	Power Ground
18	RxEIN2-	Negative LVDS differential data input (Even data)
19	RxEIN2+	Positive LVDS differential data input (Even data)
20	RxECLKIN-	Negative LVDS differential clock input (Even clock)
21	RxECLKIN+	Positive LVDS differential clock input (Even clock)
22	RxEIN3-	Negative LVDS differential data input (Even data)
23	RxEIN3+	Positive LVDS differential data input (Even data)
24	GND	Power Ground
25	NC	No contact (For AUO test only)
26	NC	No contact (For AUO test only)
27	NC	No contact (For AUO test only)
28	VCC	+5.0V Power Supply
29	VCC	+5.0V Power Supply
30	VCC	+5.0V Power Supply



Product Specification

M190PW01 V8

AU OPTRONICS CORPORATION

Note1: Start from left side

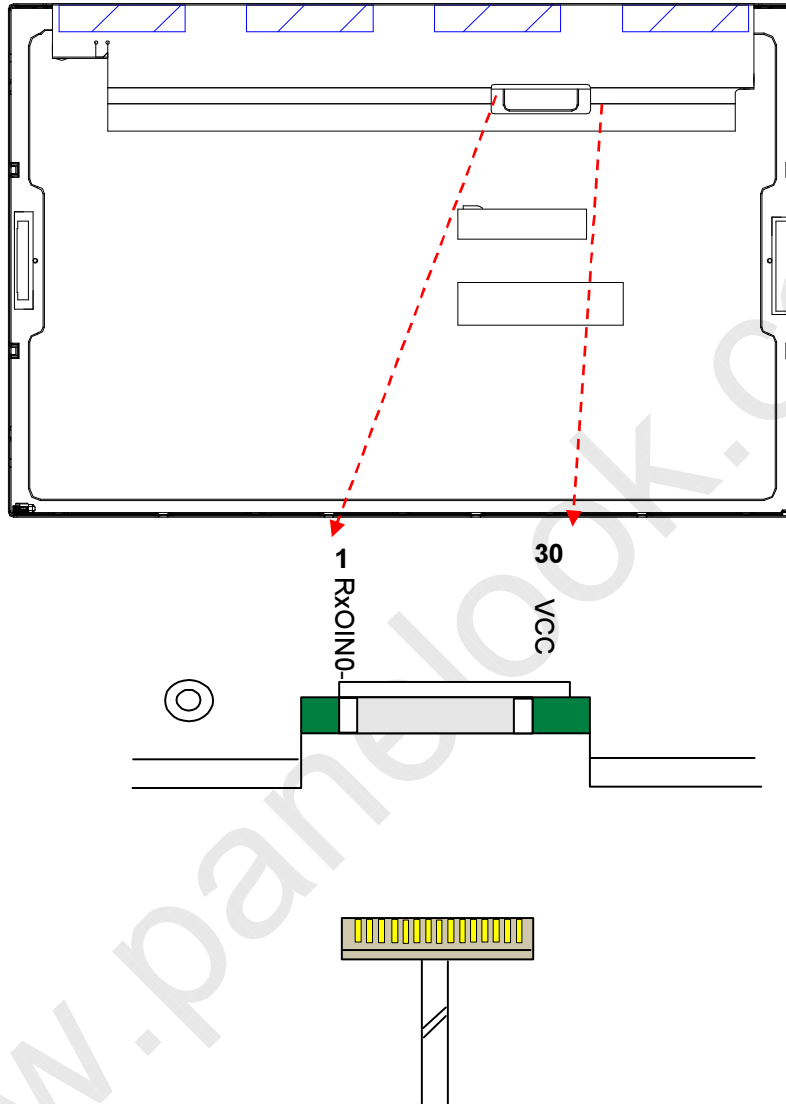

Note2: Input signals of odd and even clock shall be the same timing.

Note3: Please follow PSWG.



Product Specification

M190PW01 V8

AU OPTRONICS CORPORATION

6.4 Timing Characteristics

Basically, interface timing described here is not actual input timing of LCD module but close to output timing of SN75LVDS82DGG (Texas Instruments) or equivalent.

Item	Symbol	Min	Typ	Max	Unit	
Data CLK	1/Tclk	42.92	54.05	67.57	[MHz]	
H-section	Period	Th	870	964	2047	[Tclk]
	Display Area	Tdisp(h)	720	720	720	[Tclk]
	Blanking	Tblk(h)	150	244	1327	[Tclk]
V-section	Period	Tv	910	916	2047	[Th]
	Display Area	Tdisp(v)	900	900	900	[Th]
	Blanking	Tblk(v)	10	16	1147	[Th]
Frame Rate	F	50	60	76	[Hz]	

Note : DE mode only



Product Specification

M190PW01 V8

AU OPTRONICS CORPORATION

6.5 Timing diagram

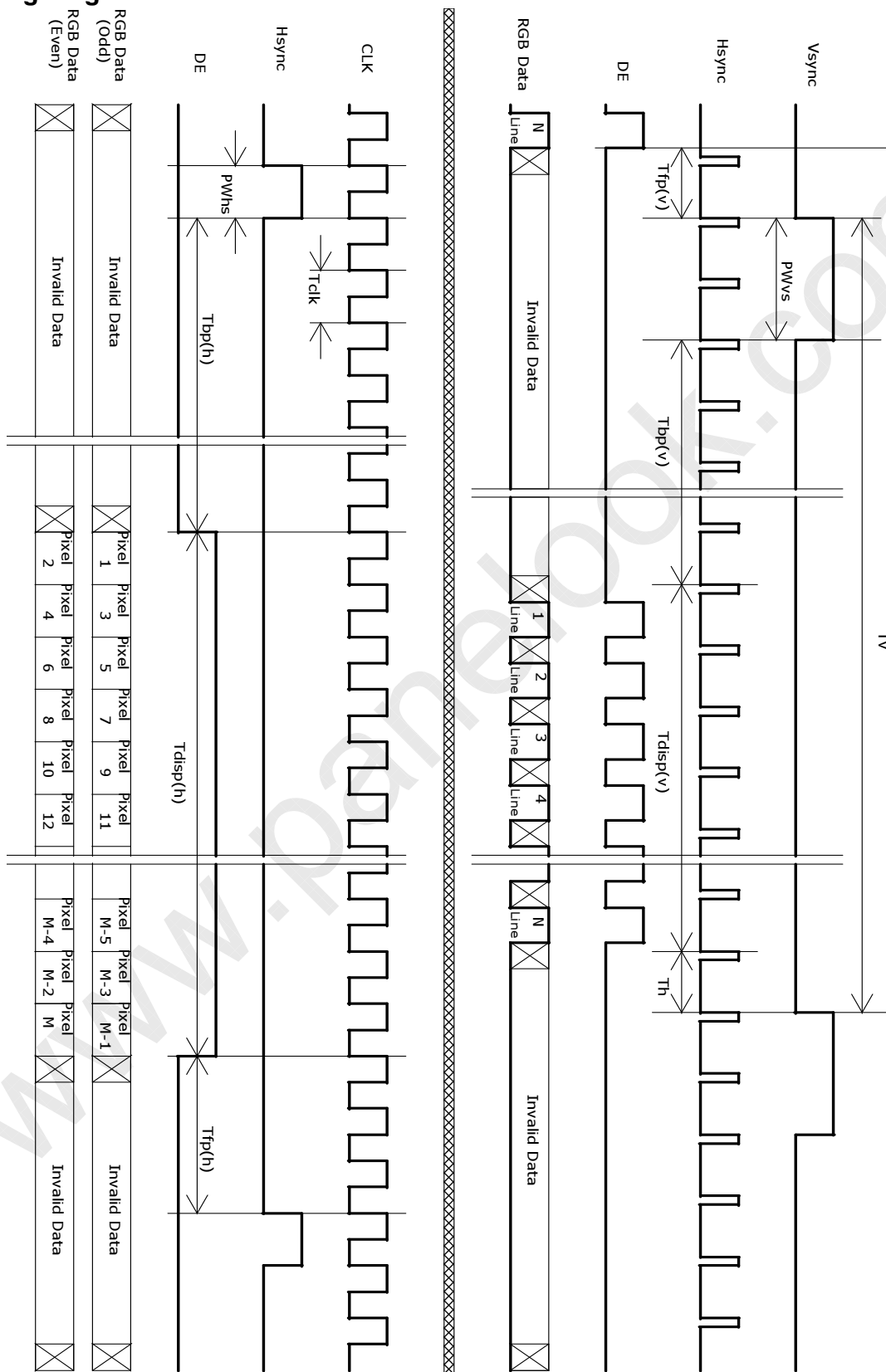



6.6 Power ON/OFF Sequence

VDD power and lamp on/off sequence are as follows. Interface signals are also shown in the chart. Signals from any system shall be Hi-Z state or low level when VDD is off.

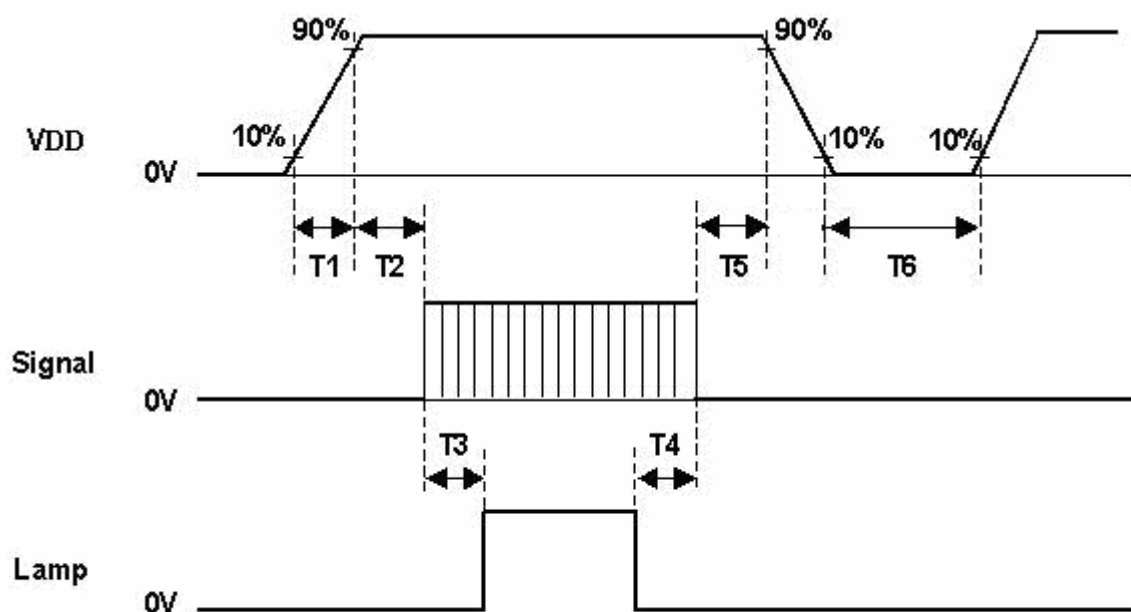

Parameter	Value		Unit
	Min.	Max.	
T1	0.5	10	[msec]
T2	0	50	[msec]
T3	500	-	[msec]
T4	200	-	[msec]
T5	0	50	[msec]
T6	1000	-	[msec]



Product Specification

M190PW01 V8

AU OPTRONICS CORPORATION

7.0 Connector & Pin Assignment

Physical interface is described as for the connector on module. These connectors are capable of accommodating the following signals and will be following components.

7.1 TFT LCD Module

Connector Name / Designation	Interface Connector / Interface card
Manufacturer	JAE or SC(慶良)
Type Part Number	FI-XPB30SRL-HF11 093F30-B0T01A
Mating Housing Part Number	FI-X30HL-T (Locked Type) FI-X30S-H (Unlocked Type) or equivalent

7.1.1 Pin Assignment

Pin#	Signal Name	Pin#	Signal Name
1	RxOIN0-	2	RxOIN0+
3	RxOIN1-	4	
5	RxOIN2-	6	RxOIN2+
7	GND	8	RxOCLKIN-
9	RxOCLKIN+	10	RxOIN3-
11	RxOIN3+	12	RxEIN0-
13	RxEIN0+	14	GND
15	RxEIN1-	16	RxEIN1+
17	GND	18	RxEIN2-
19	RxEIN2+	20	RxECLKIN-
21	RxECLKIN+	22	RxEIN3-
23	RxEIN3+	24	GND
25	NC	26	NC
27	NC	28	VCC
29	VCC	30	VCC



Product Specification

M190PW01 V8

AU OPTRONICS CORPORATION

7.2 Backlight Unit

This connector is mounted on LED light-bar.

Connector Name / Designation	Driver Board Connector
Manufacturer	(1) ENTERY INDUSTRIAL CO., LTD (2) CHIEF LAND Electronic Co., Ltd. (3) CVILUX CORPORATION.
Type Part Number	(1) 3707K-Q06N-01 (2) 116B06-100000-M2-R (3) CI1406M1HRE-NH
Mating Type Part Number (Housing)	(1) H112K-P06N-01B (2) - (3) CI1406SL000-NH

7.2.1 Pin assignment

Pin no.	Signal name
1	IRLED (current out)
2	
3	
4	VLED (voltage in)
5	IRLED (current out)
6	IRLED (current out)



Product Specification

M190PW01 V8

AU OPTRONICS CORPORATION

8.0 Reliability Test

Environment test conditions are listed as following table.

Items	Required Condition	Note
Temperature Humidity Bias (THB)	Ta= 50□, 80%RH, 300hours	
High Temperature Operation (HTO)	Ta= 50□, 50%RH, 300hours	
Low Temperature Operation (LTO)	Ta= 0□, 300hours	
High Temperature Storage (HTS)	Ta= 60□, 300hours	
Low Temperature Storage (LTS)	Ta= -20□, 300hours	
Vibration Test (Non-operation)	Acceleration: 1.5 Grms Wave: Random Frequency: 10 - 200 Hz Sweep: 30 Minutes each Axis (X, Y, Z)	
Shock Test (Non-operation)	Acceleration: 50 G Wave: Half-sine Active Time: 20 ms Direction: ±X, ±Y, ±Z (one time for each Axis)	
Drop Test	ht: 60 cm, package test	
Thermal Shock Test (TST)	-20□/30min, 60□/30min, 100 cycles	1
On/Off Test	On/10sec, Off/10sec, 30,000 cycles	
ESD (Electro Static Discharge)	Contact Discharge: ± 8KV, 150pF(330Ω) 1sec, 8 points, 25 times/ point.	2
	Air Discharge: ± 15KV, 150pF(330Ω) 1sec 8 points, 25 times/ point.	
Altitude Test	Operation:10,000 ft Non-Operation:30,000 ft	

Note 1: The TFT-LCD module will not sustain damage after being subjected to 100 cycles of rapid temperature change. A cycle of rapid temperature change consists of varying the temperature from -20°C to 60°C, and back again. Power is not applied during the test. After temperature cycling, the unit is placed in normal room ambient for at least 4 hours before power on.

Note 2: EN61000-4-2, ESD class B: Certain performance degradation allowed
 No data lost
 Self-recoverable
 No hardware failures.



Product Specification

M190PW01 V8

AU OPTRONICS CORPORATION

9.0 Shipping Label

The label is on the panel as shown below:

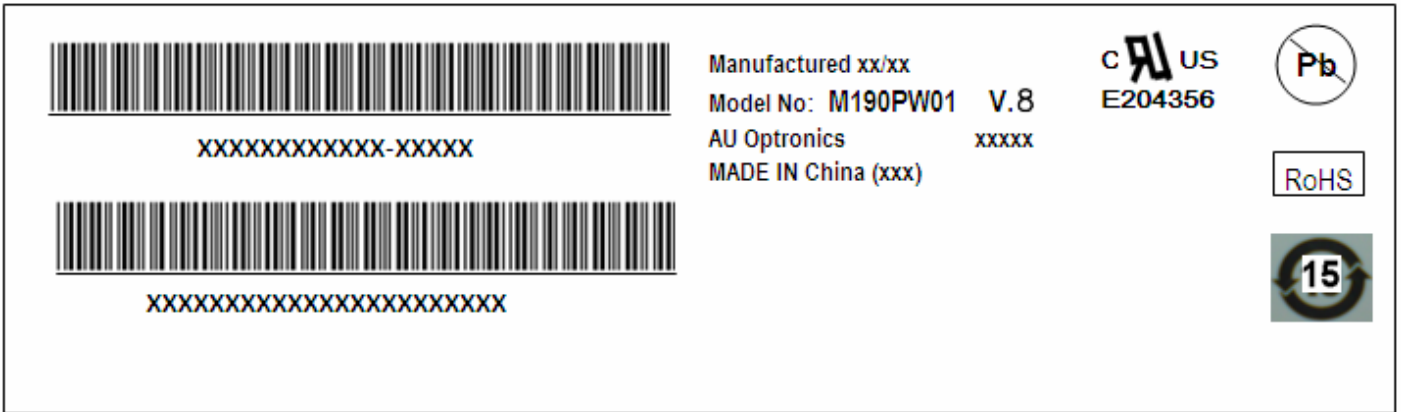

A



Product Specification

M190PW01 V8

AU OPTRONICS CORPORATION

10. Packing Specification

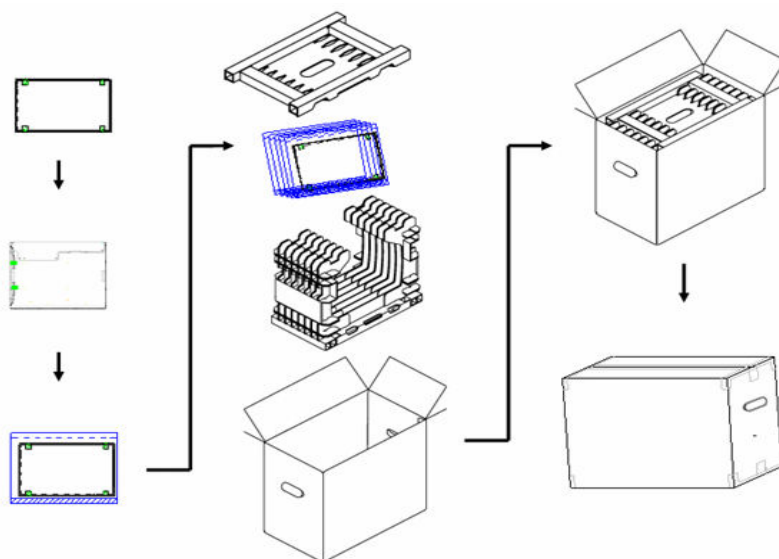

2. Pallet and shipment information

	Item	Specification			Remark
		Q'ty	Dimension	Weight(kg)	
1	Panel	1	428(H)mm x 278(V)mm x 10.3(D)mm	1.45	
2	Cushion	1	-	1.80	
3	Box	1	480(L)mm x 276(W)mm x 430(H)mm	0.95	without Panel & cushion
4	Packing Box	8 pcs/Box	480(L)mm x 276(W)mm x 430(H)mm	14.35	with panel & cushion
5	Pallet	1	1140(L)mm x 980(W)mm x 138(H)mm	13	
6	Pallet after Packing	16 boxes/pallet	1140(L)mm x 980(W)mm x 1428(H)mm	229.6	

11.0 Mechanical Characteristics

